

OPERATOR'S MANUAL



VE

ROTARY ELECTRIC VIBRATOR

TABLE OF CONTENTS

<u>TITLE</u>	<u>PAGE</u>
General Precautions and Safety.....	2
Wiring Diagrams.....	3
Electrical Installation.....	4
Mechanical Installation.....	5
Mounting guidelines	6
Force Adjustment.....	7
Bearing Lubrication and Maintenance.....	8
Sizing.....	10
Winding Protection Tips.....	11
Nameplate.....	12
Part List.....	13
Single Phase.....	14

GENERAL PRECAUTIONS AND SAFETY

To ensure a correct installation it is recommended that the installation should be done by qualified personnel only.

Always install the vibrator with *thermal overload protection!*

If an overload protection is not used, the vibrator can be destroyed and warranty would be void.

Do not allow motor current to exceed nameplate rating.

If vibrator is operated continuously with line current above nameplate rating, it will be damaged!

Thermistors and thermostats are intended for motor winding protection or to limit external motor surface temperatures. They complement but do not replace overload protection.

Fuses are surge protectors and will complement thermal overloads.

Fuses can **not** be used **as** thermal overloads and **do not replace** thermal overloads.

Do **not** use **multiple vibrators** with only a **single overload**
Each motor needs its own dedicated overload.

Vibrator is designed for an ambient temperature range of -24° to 105°

For operations beyond these limits please consult factory since bearing lubrication schedules are different and vibrator might require a rating change.

WIRING DIAGRAMS

9 LEADS

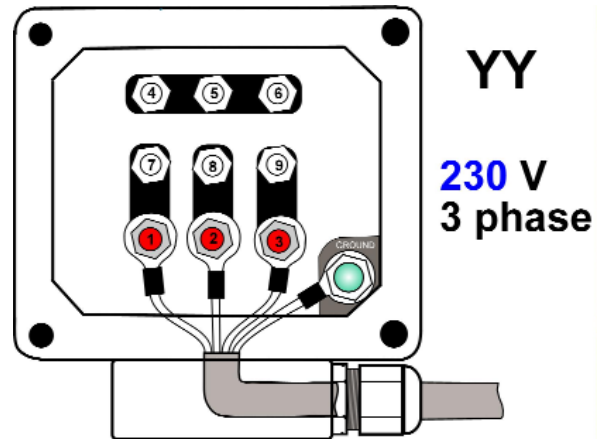
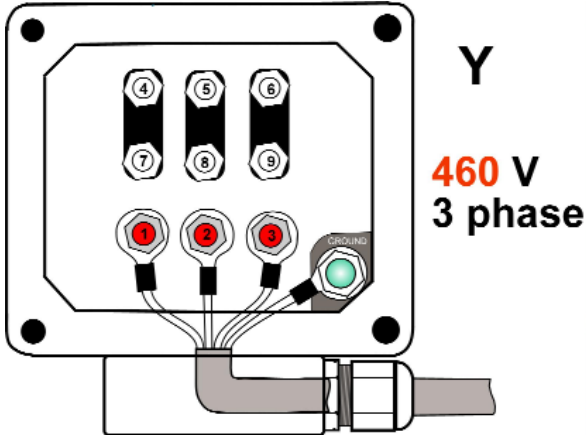

6 LEADS

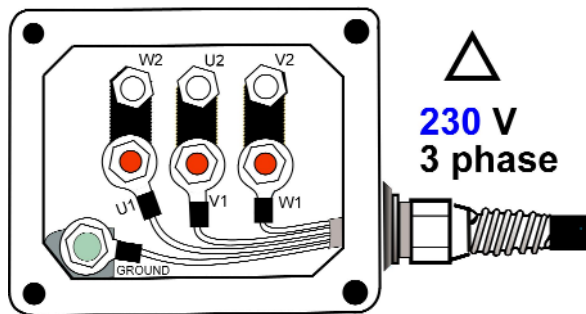
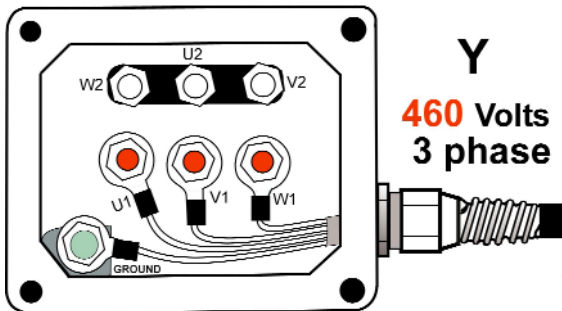

380 Volts-50Hz

575 Volts -60Hz

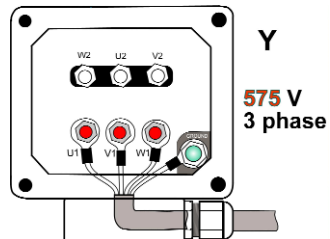
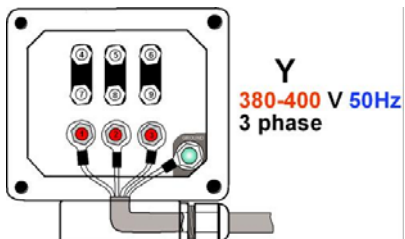

ELECTRICAL INSTALLATION

Terminal block comes with nine leads
 Standard voltage connections are
 Y = 460 (575) volts three-phase
 YY = 230 volts three-phase

Vibrator must be grounded using power supply ground wire.
Failure to properly ground vibrator can cause severe injury or death.

Amps Reading

Using an amp meter, check that the current absorbed in the three phases is equal or lower to the amps indicated in the nameplate

Connection to Power Supply

This operation must be executed by qualified personnel only.

Power supply must be disconnected during installation!

Use flexible cable, with 4 leads.

Cable section must be appropriate for motor amps draw (max. density = 4A/mm²)

Cable grip should match the cable size in order to prevent water or humidity from entering the terminal block. Allow for voltage drop for cables exceeding recommended length.

CABLE DIAMETER	
<i>Suggested min. size</i>	<i>Range of models</i>
0.35" - 0.45" (9-12 mm)	36/95 -35/400 18/150
0.5" - 0.75" (12-15 mm)	36/660-36/4000 18/450 -18/5000 12/600 - 12/2800
0.65" - 0.75" (16-19 mm)	36/5000-36/12000 18/6000-18/18000 12/6000-12/17500
0.75" - 0.85" (19 - 21 mm)	18/20000-18/25000 12/18000-12/25000



When running the cord to the vibrator, make sure the cord voltage rating equals or exceeds the voltage at which you will be operating the vibrator. It must have a minimum temperature rating of 221 F and a minimum diameter(as shown in the table above)

If the wire does not have the right diameter, the cord grip will not tighten properly and the vibrator could be damaged by moisture or material getting into the terminal block. If the cord is damaged, it could short the power supply or short to ground causing damage to the vibrator.

When wiring vibrator, leave slack in electrical cable so that cable does not become too tight during vibration cycle causing stress on wire connections and preventing moisture from running down the cable into the terminal block.

For equipment using two vibrators, the two motors must be electrically interlocked. If using a single contactor, each motor must be provided with separate overload protection. The motor control circuit must be arranged so that if one motor becomes de-energized, the other motor will automatically and immediately become de-energized.

MECHANICAL INSTALLATION

Never weld structure with vibrator mounted and wired! Welding may cause damage to motor windings and bearings.

Vibrators last longer and are more effective when bolted to a rigid mount.

Mounting plate must be totally flat!

Warped surface can cause body stress and possible cracks.

Take an amp reading to make sure that the unit is not drawing more than the specified amps.

In situations of high amp draw, reinforce the mounting area or relocate it until rated amp draw is achieved.

BOLTS

When changing or moving a vibrator please **use only new Grade 5 (or 8) bolts!**

Old bolts can break and cause damage to vibrator or structure.

Always use tooth lock washers or compression spring lock washers

Locking nuts are also recommended.

Do **not** use split **lock washers**: damage to the vibrator could result.

Do not use regular washers: bolts will get loose and vibrators could fall.

Cross tighten mounting bolts!

If not, the vibrator casting could be damaged

At startup retighten after two hours of operation!

Periodically check bolts to ensure tightness.



MOUNTING BOLTS & TORQUE SPECS				
FRAME SIZE	AMERICAN		METRIC	
	Bolt Size	Torque	Bolt Size	Torque
	Grade 5	Ft-lbs	Grade 8.8	Kgm
0	5/16"-.18 NC	17	M8	2
1	5/16"-.18 NC	17	M8	2
2	1/2"-13 NC	75	M12	8
3	1/2"-13 NC	75	M12	8
4A	5/8" - 11 NC	132	M16	20
4B	5/8" - 11 NC	132	M16	20
15A	5/8" - 11 NC	132	M16	20
15B	5/8" - 11 NC	132	M16	20
20	3/4" - 10 NC	290	M20	40
30	7/8" -9 NC	430	M22	55
50	1" - 8 NC	650	M24	70
70	1"-1/8" - 8 NC	650	M28	90
70B	1"-1/8" - 8 NC	650	M28	90
120A	1-1/4" -- 8 NC	1100	M 30	130
120B	1-1/4" -- 8 NC	1100	M 30	130
120C	1-1/4" -- 8 NC	1100	M 30	130

FRAME TABLE							
00	01	2	3	4A	4B	15A	15B
VE1/36/95 VE3/36/95	VE*/36/120 VE*/36/250 VE*/36/400 VE3/18/150	VE1/36/660 VE3/36/660 VE3/18/450	VE1/36/1050 VE3/36/1050 VE3/18/900 VE3/18/1200 VE3/12/600	VE3/36/1650 VE3/18/1500 VE3/12/800	VE3/36/2200 VE3/36/2800 VE3/18/2200 VE3/12/1000	VE3/36/3000 VE3/18/3500 VE3/12/2000 VE3/09/1500	VE/36/4000 VE3/18/4600 VE3/12/2800 VE3/09/2000
20	30	50	70	70B	120A	120B	120C
VE3/36/5000 VE3/18/6000 VE3/12/4000 VE3/09/3000	VE3/36/7000 VE3/18/8000 VE3/12/6000 VE3/09/5000	VE3/36/10000 VE3/18/10000 VE3/12/10000 VE3/09/8000	VE3/36/12000 VE3/18/15000 VE3/12/15000 VE3/09/12000	VE3/36/20000 VE3/18/17500 VE3/12/18000 VE3/09/14000	VE3/18/18000 VE3/12/18700 VE3/09/15000 VE3/09/18000	VE3/18/20000 VE3/12/20000 VE3/09/21000	VE3/18/25000 VE3/12/25000 VE3/09/24000

MOUNTING GUIDELINES

Vibrator Mounting to Hoppers and Bins

- The purpose of rotary vibration on bins, hoppers and chutes is to transmit vibration through the wall into the product contained inside.

- **The vibrator should always be installed with a proper mounting made of channel iron** stitch welded to the wall of the bin's cone **with a steel plate welded on top!**

- Maximum vibration transfer efficiency occurs when the vibrator is rigidly mounted, and the force and frequency are transmitted over a large reinforced surface area.

- If structure is not made rigid, the vibrator might draw high amperage and move material less efficiently.

- Regularly examine the mounted vibrator for loose bolts, nuts, structural cracks

(gussets, legs, W-beam(I-beam) or channel mount, etc.), to ensure performance of the unit. Correcting these will reduce structural damage, reduce noise levels and increase vibration transfer.

- When mounting the vibrator, make sure the mounting surfaces are free of dirt, rust, scale, paint, grease, oil, etc., and dry.

- Install the vibrator in lowest 1 / 3 sloped cone section.

- A mounting channel or W-beam (better!) should be as long as is practical to install (2/3 the length of the slope - minimum), and as wide as the vibrator base. It should be stitch welded to the hopper, bin, or chute to be vibrated. Weld 3", skip 1½" - never weld closer than 1" from the ends or corners of the W-beam (I-beam)

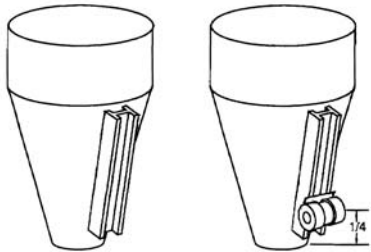
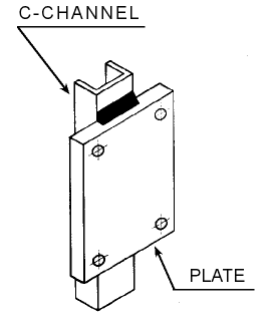

If using a channel it can be notched to provide access to mounting bolts.

- Never weld the structure with the vibrator mounted and wired.

Welding may cause damage to motor windings and bearings.

- This setup may vary depending on the problem in the cones, like ratholing or bridging.

Multiple Mount

For thin binwalls two or more smaller vibrators should be used instead of a larger one.

If **two vibrators** are required, they should be mounted 180° apart.

For **ratholing** and clinging the units should be mounted at ¼ and at 1/3 up from the discharge opening.

For **bridging** the units should be mounted at 1/3 and 2/3 up from the discharge opening.

If **three vibrators** are needed, they should be mounted 120° apart.

For ratholing the units should be mounted at ¼, 1/3 and ½ up from the discharge opening.

For bridging the units should be mounted at ¼, ½ and ¾ up from the discharge opening.

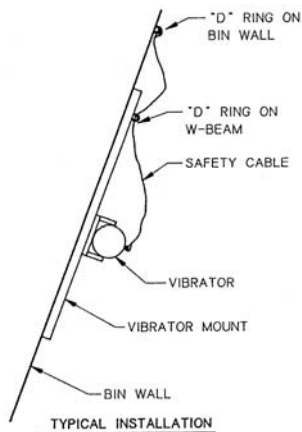
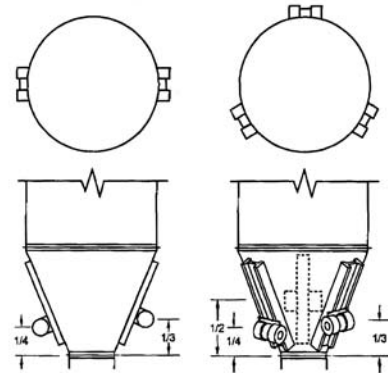

SAFETY CABLE

Mounted vibrators should always be attached to a safety cable securing the vibrator to the structure.

Do not attach the safety cable to the channel.

Without cable, vibrator (and even channel) could fall and cause injury.

For proper cable installation and sizing contact your local vibrator distributor or vibrator specialist.

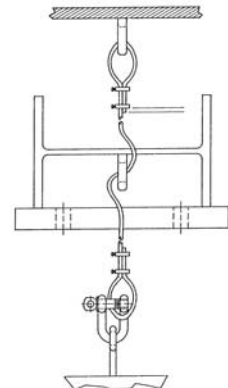

SIZING & MOUNTING

WEIGHT OF THE MATERIAL ON THE BIN'S CONE (lbs)	FORCE OUTPUT NEEDED (lbs)	MINIMUM WALL THICKNESS	MINIMUM C-CHANNEL SIZE	MINIMUM PLATE THICKNESS
1000	100	12 gauge	3"	1/4"
2000	200	12 gauge	3"	3/8"
3000	300	11 gauge	4"	1/2"
5000	500	10 gauge	4"	1/2"
10000	1000	3/16"	5"	5/8"
20000	2000	1/4"	6"	5/8"
30000	3000	1/4"	8"	3/4"
40000	4000	3/8"	8"	1"

Using channel sizes (*and plates*) lower than the recommended above would increase mount flexibility and produce an unwelcome vibrator amp draw rise.

The **sturdier** the mount the **more force** is transferred to the hopper, the **lower** is the **amp draw**.
The **weaker & flexible** is the mount the **less force** is transferred, the **higher** is the **amp draw**.

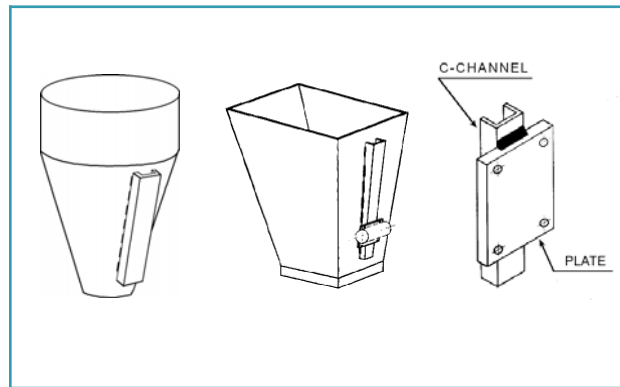
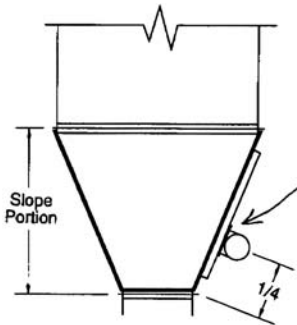

SQUARE HOPPER Mounting options		
Standard C-channel mounting	Inverted channel Easy nut tightening	I-beam Easy nut tightening
ROUND HOPPER Mounting options		
Standard C-channel mounting	I-beam Easy nut tightening	Double L-Channel Easy to install but to be used only with small vibrators.

FORCE ADJUSTMENT

Eccentric Weights

When checking shaft rotation, remove end caps only if absolutely necessary and do not let vibrator run more than 5 seconds; keep hands away from the rotating weights.

Weights will crush fingers. Unprotected weights can be deadly

Never operate the vibrator with the end caps removed!

Do not run vibrator with eccentric weights removed. Bearing can get severely damaged.

Standard Weight Setting

Vibrators come factory set at

70% (of max force) at 3600 rpm

30% at 1800 rpm

50% at all other speeds

How to adjust eccentric weights

Force output adjustment is obtained by changing eccentric weights settings.

1. Make sure the power supply is off and the cable is disconnected.

2. Remove the end caps

Eccentrics are made of two overlapping steel masses.

3. Once the blocking end-bolt has been pulled out the outer mass can be adjusted to the needed position.

4. Adjust to the lowest setting required to move the material.

this will increase life and reduce energy costs.

5. Adjust both sets of eccentric weights to the same setting number (mirror images), or force output will be uneven and damage vibrator.

6. While reinstalling end caps, o-rings should be carefully placed into their original position(Frame Size 4 and higher).

With smaller vibrators, when untightening the shaft nut, the use of a vice grip might be helpful

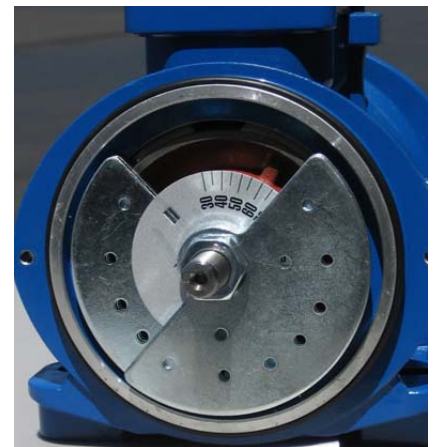
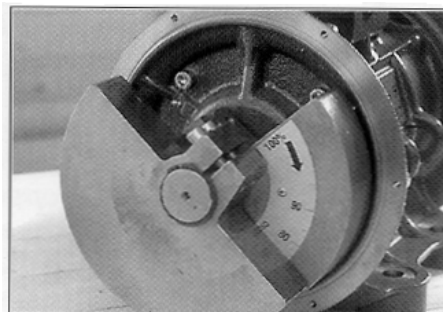

BEARING LUBRICATION

Two options are recommended for electric vibrators.

Option 1.

GREASE REPLENISHMENT

Bearing come pregreased: they are not to be greased when new!

Apply proper electric vibrator grease every 1200 hours (1000 hours for speeds of 3600 rpm).

Make sure not to exceed the amount specified in the lubrication table

Do not mix grease types! The refilling grease must be the same as the grease used previously.

Before pushing the grease through the fittings, make sure the fittings are clean, in order to avoid dust in the bearings.

Option 2.

GREASE SUBSTITUTION

Replace with brand new grease every 5000 hours.

Take bearing apart, clean and reapply brand new grease.

Clean bearings thoroughly and reapply new grease not to exceed the amount specified in the lubrication table.

LUBRICATION TABLE							
VE FRAME	BEARING MODEL	SKF SUFFIX	FAG SUFFIX	GREASE ADDITION		GREASE SUBSTITUTION	
				WORKING HOURS	QUANTITY PER BEARING OUNCES	WORKING HOURS	QUANTITY PER BEARING OUNCES
0	6202	ZZ.C3	-	none	(sealed)	none	(sealed)
1	6202-6302	ZZ.C3	-	none	(sealed)	none	(sealed)
2	6303	ZZ.C3	-	none	(sealed)	none	(sealed)
3	6306	ZZ.C3	-	none	(sealed)	none	(sealed)
4A	6307	ZZ.C3	-	none	(sealed)	none	(sealed)
4B	NJ 307 E	CP.C4	TVP2.C4	1200	1/4	5000	1/2
15A	NJ 308 E	CP.C4	TVP2.C4	1200	1/3	5000	2/3
15B	NJ 2308 E	CP.C4	TVP2.C4	1200	1/2	5000	1
20	NJ 2309 E	CP.C4	TVP2.C4.QP51	1200	2/3	5000	1
30	NJ 2311 E	CP.C4	TVP2.C4.QP51	1200	1	5000	1 1/2
50	NJ 2313 E	CP.C4	TVP2.C4.QP51	1200	2	5000	3
70	NJ 2315 E	CP.C4	TVP2.C4.QP51	1200	2	5000	4
70B	NJ 2317 E	CMA.C4	M1A.C4.QP51	1000	3	5000	5
120A	NJ 2317 E	CMA.C4	M1A.C4.QP51	1000	3	5000	5
120B	NJ 2318 E	CMA.C4	M1A.C4.QP51	1000	3	5000	6
120C	NJ 2320 E	CMA.C4	M1A.C4.QP51	1000	5	5000	9

FRAME TABLE							
00	01	2	3	4A	4B	15A	15B
VE1/36/95 VE3/36/95	VE1/36/120 VE3/36/120 VE1/36/250 VE2/36/250 VE1/36/400 VE3/36/400 VE3/18/150	VE1/36/660 VE3/36/660 VE3/18/450	VE1/36/1050 VE3/36/1050 VE3/18/900 VE3/18/1200 VE3/12/600	VE3/36/1650 VE3/18/1500 VE3/12/800	VE3/36/2200 VE3/36/2800 VE3/18/2200 VE3/12/1000	VE3/36/3000 VE3/18/3500 VE3/12/2000 VE3/09/1500	VE3/36/4000 VE3/18/4600 VE3/12/2800 VE3/09/2000
20	30	50	70	70B	120A	120B	120C
VE3/36/5000 VE3/18/6000 VE3/12/4000 VE3/09/3000	VE3/36/7000 VE3/18/8000 VE3/12/6000 VE3/09/5000	VE3/36/10000 VE3/18/10000 VE3/12/10000 VE3/09/8000	VE3/36/12000 VE3/18/15000 VE3/12/15000 VE3/09/12000	VE3/36/20000 VE3/18/17500 VE3/12/18000 VE3/09/14000	VE3/18/18000 VE3/12/18700 VE3/09/15000 VE3/09/18000	VE3/18/20000 VE3/12/20000 VE3/09/21000	VE3/18/25000 VE3/12/25000 VE3/09/24000

Do not overgrease!

Overgreasing will force the bearing temperature to rise. When the temperature exceeds the maximum safety limit, bearings will malfunction causing the vibrator to fail.

For optimal performance

use only Factory certified grease "KLUEBER STAUBURANGS NBU 8 EP".

For additional information and pricing please call directly KLUEBER CORPORATION at 603-434-7704

If a different grease is used, vibrator can be damaged and warranty will be void.

Do not grease any other part of the motor.

Bearing Specifications

Vibrators have special long lasting bearings with a unique code specifying:

1. Bearing type
2. Cage size
3. Fit
4. (QP 51 in FAG bearings)

Example NJ-2310-E-TVP2-C4.

When replacing the bearings make sure the new bearings have the same exact and complete code. If it can not be found by the bearing house please contact the manufacturer.

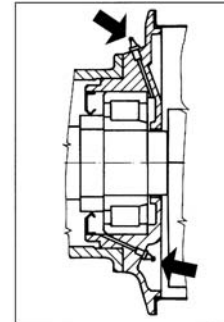

Substituting originals with improper bearings (not matching the exact code) will cause the vibrator to fail.
Bearing fit for the VE Series is C4

Running the vibrator with eccentric weight removed will damage bearings.

Bearing Replacement Procedure

This operation must be executed by qualified personnel only.

To proceed and replace the bearings operate as follows

1. Remove screws, lateral covers, retaining rings, weights and keys.
2. Extract bearing housing.
3. Using the two tapped holes in the bearing housing and two bolts, push out slowly bearing and seal. Make sure you push evenly at both sides.
4. Extract rotor shaft from the body.
5. With a bearing extractor, pull out bearing's inner ring.
6. Check the bearing housing and the rotor shaft. Should they be damaged or worn, they must be replaced.
7. Remount the bearings. With the use of a press, push them completely into their housing.
8. Force new grease in between the roller cage and the outer ring.
9. The rest of the vibrator assembly, follow the disassembly procedure in reverse.

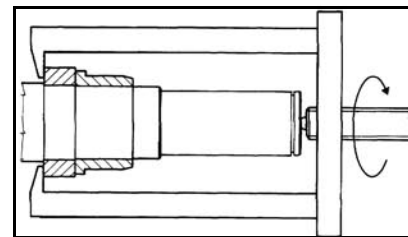

During re-assembly always use new screws, washers and seals, making sure that the seals are not damaged during installation.

CAUTION! During bearing disassembly and reassembly, it is imperative for the flange to be kept perfectly in line with the vibrator body! Any misalignment could cause permanent damage to the bearings.

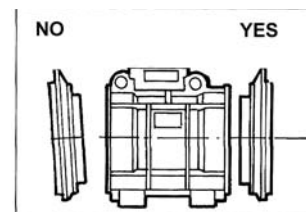

WINDING MAINTENANCE

INCORRECT VOLTAGE

Even a 5% difference on a larger motor could have a negative effect.

Besides a thorough maintenance and testing program, one of the best ways to guarantee economical performance and long motor life is to make sure your motors operate at nameplate voltage.

Applying too high a voltage may reduce the motor's efficiency and increase core losses. This, in turn, shortens the motor life by overheating the insulation system.

Low voltage can also shorten motor life. Operating on too low a voltage reduces the motor's effective horsepower. For example, a 5-hp motor operated at 10% below rated voltage becomes a 4-hp motor. The motor will try to drive the load it was intended to drive, become overloaded, draw more current and overheat. The result -- premature failure.

VOLTAGE FLUCTUATIONS

Voltage fluctuations due to poor power supply or wrong cable size need to be kept under control. Frequent or extended voltage variations can be fatal for the motor.

Proper safeguards should be installed.

VOLTAGE UNBALANCE

Unbalance also can be lethal for the motor. Operating a three-phase motor with an unbalanced voltage can also cause serious overheating that will shorten its life dramatically. Voltage unbalance should not exceed 2%.

MOISTURE

Moisture is detrimental to long motor life because it will deteriorate the insulation. To prevent condensation, one of two common methods are usually effective. One is to install electric heaters in the motor. The other is to apply a low dc voltage to one phase of the motor windings whenever the motor is at rest. With either method, the objective is to keep the temperature of the windings 10°F to 20°F above the ambient temperature.

Protect electric vibrators from excessive water. This series is not designed to operate submerged.

INSULATION

Class F insulation enhances the safety under continuous operating conditions and at high ambient temperatures. The motor winding is drip impregnated with synthetic resin to withstand high "g" forces. Mechanical protection IP 65-7

TEMPERATURE

- External temperature range is -40° to +110° F.
- Vibrator's body temperature should not exceed 210° F
- Bearing max temperature is 240° F

STORAGE

If the vibrator motor is to be stored for a long period the location must be covered. Ambient temperature should be between 40° and 120° F and relative humidity should not be higher than 60%.

NOISE

After a longer operating period, the increased radial clearance of the bearing, together with the elimination of the excess grease, causes a normal increase of the noise of the vibrator motor. In certain applications, the combination of machine/vibrator motor can cause noise emissions high enough to require the use of individual ear protectors.

NAME PLATE

Name Plate contains important data regarding manufacturer's specifications.

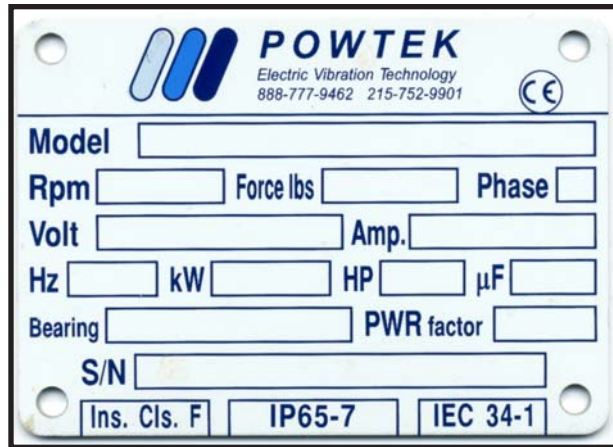

Model:	Model Number
Rpm:	Vibrations per Minute
Force Lbs:	Centrifugal Force in Lbs (1Lb Force Output = 4.45 Newton)
Phase:	3 for Three-Phase or 1 for Single Phase
Volt:	Voltage (usually 115v or 230/460v)
AMP:	AMP draw at the above voltage
Hz:	Power Supply Frequency (Usually 60Hz)
KW in:	Absorbed Power in Kilowatts
HP out:	Produced Power in Hp
Conn.:	Wiring Diagram (Usually 2- see page 3)
nF:	Size of the Capacitor in Microfarad (Single Phase Only)
PWR factor	Also called "Cos Fee" is the Motor Efficiency Factor
Bearing	Bearing model
S/N:	Serial Number
INS:	Insulation Class
IP:	Electrical Protection Rating IP-65 6= Totally protected against dust 5= Protected against low pressure jets of water from all directions
IEC:	International Electric Code Regulation

PARTS LIST

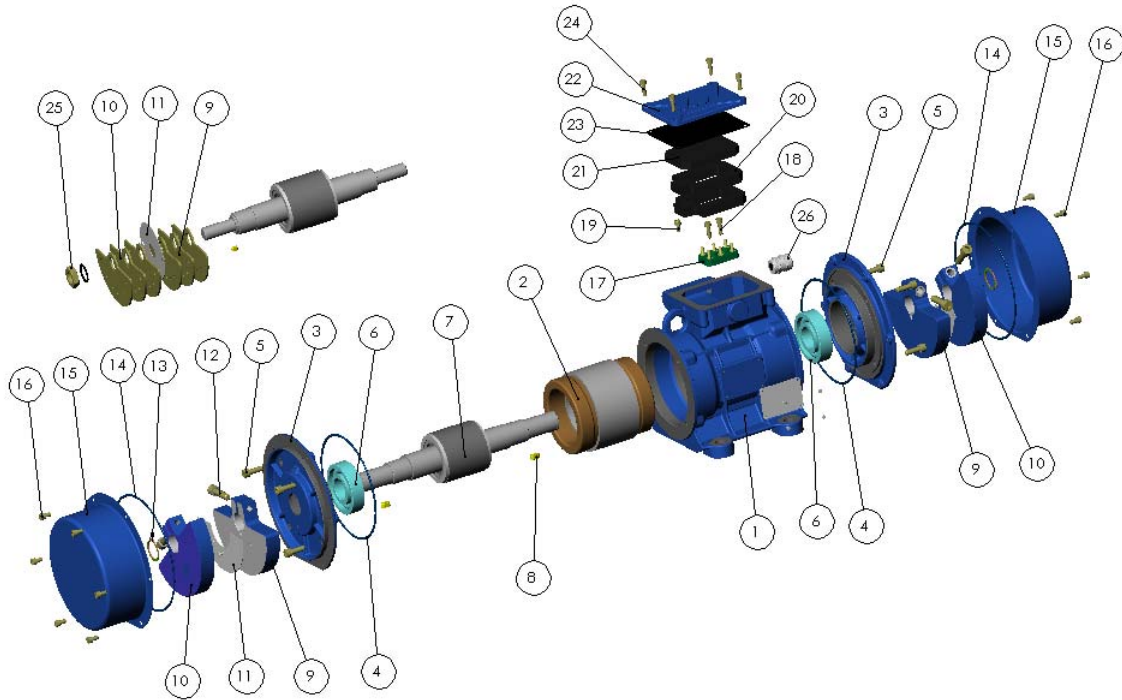

PART	DESCRIPTION	PART	DESCRIPTION
1	Housing	14	O-Ring
2	Stator	15	End Cap
3	Bearing Housing	16	End Cap Screw
4	O-Ring	17	Terminal Block
5	Screw	18	Wire Connector Screw
6	Bearing	19	Ground Screw
7	Rotor	20	Lower Rubber Block
8	Key	21	Upper Rubber Block
9	Inner Weight	22	Terminal Block Cover
10	Outer Weight	23	Gasket
11	Adjusting Dial Plate	24	Lid Screw
12	Eccentric Weight Blocking Screw *	25	Eccentric Weight Blocking Screw **
13	Retaining Ring	26	Cable Grip

* frame 4 and higher

** frame 0 to 3

SINGLE PHASE

CONTROL BOX FOR SINGLE PHASE ELECTRIC VIBRATORS



ENCLOSURE BOLT HOLE PATTERN

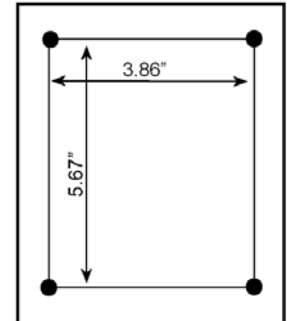

Control Box comes **standard with:**

1. On-Off push button
2. Reset push button
3. Thermal **Overload** Protection
4. Capacitor
5. Plastic box rated for outside applications(NEMA 4)
6. Complete wiring connections between vibrator, box and power supply.

plus upon request:

7. Electronic Timer

WIRE COLOR CODES

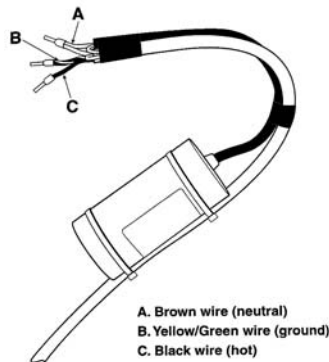

TIMER

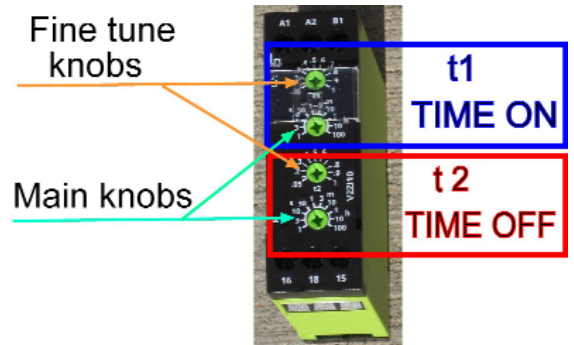

WIRING DIAGRAMS

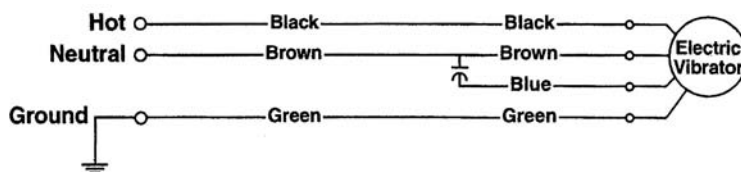

Vibrator without Control Box

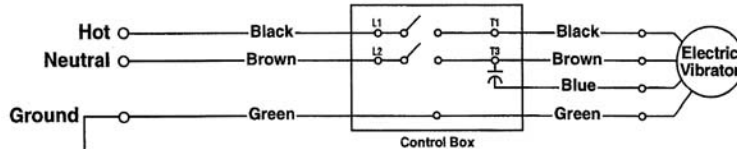

Vibrator with Control Box

CONTROL BOX WITH TIMER OPTION

